

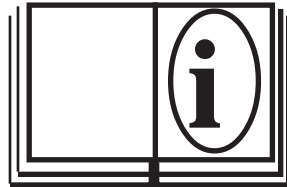

# Truck Mounted Valve Operator

Model TM-6, TM-6B



	<b>PIPE &amp; VALVE</b>
	MAINTENANCE PRODUCTS
Mod. <b>TM-6, 6B</b> S/N: <input type="text"/> <input type="text"/> <input type="text"/> <input type="text"/> <input type="text"/> <input type="text"/> <input type="text"/> <input type="text"/>	
E.H. Wachs Company 600 Knightsbridge Parkway, Lincolnshire, IL 60069	

Part Number: 07-MAN-01

Revision No: 2

Revised:  
April, 98



# TM-6 TRUCK MOUNTED VALVE OPERATOR

## TABLE OF CONTENTS

SECTION I	INTRODUCTION	4
SECTION II	SAFETY INSTRUCTIONS	5
SECTION III	MACHINE SPECIFICATIONS	6
SECTION IV	SET UP & OPERATION	7-10
	A. TM-6 Installation Instructions	7-8
	B. TM Controller	9
	C. Operation Instructions	10
SECTION V	MAINTENANCE	11
SECTION VI	TM-6 TROUBLESHOOTING	14-15
	TM-6B TROUBLESHOOTING	16-17
SECTION VII	OPERATION MODE COMPARISON TABLE	20
SECTION VIII	PARTS LISTS AND EXPLODED VIEW DRAWINGS	22-29
SECTION IX	WIRING DIAGRAMS AND VALVE EXCECISE LOG	32-35
SECTION X	PARTS ORDERING INFORMATION	36

# TM-6 TRUCK MOUNTED VALVE OPERATOR

## SECTION I

## INTRODUCTION

The E.H. Wachs TM-6, truck mounted valve operator is a permanently mounted, heavy duty, hydraulic valve turner to "**Automatically**" operate 6" through 96" valves.

The TM-6 offers the same rugged design, power and reliability as it's TM-2, TM-3, and TM-5 predecessors. Now, combined with a new "**Automatic Control System**" the TM-6 is designed to make valve turning easy for all utilities and assures maximum valve protection.

The E.H. Wachs company has taken 50 years of valve turning and exercising experience, gathered from utilities worldwide and has programmed this safe and accepted method into the TM - 6. Now even the *inexperienced* operator has the ability to turn hard to operate valves without knowing direction, loosen seized valves and exercise valves safely and efficiently.



### MICROPROCESSOR CONTROLLER:

The TM-6 Microprocessor Controller is a hand held pendant type, utilizing a powerful 9.216 MHz Z180 processor to run Wachs' copyrighted valve exercising program for safe and easy valve turning.

Built in a durable cast aluminum housing which is watertight and impact resistant, the TM-6 features a backlit LCD display for easy visibility, day or night. It also provides a tactile key pad for positive feel data input.

The pendant, when not in use, is secured in a snap-in closure at the front of the machine for easy access.



# TM-6 TRUCK MOUNTED VALVE OPERATOR

## SECTION II

## SAFETY INSTRUCTIONS

Since 1883, EHWachs has built a reputation for quality and a commitment to consumer satisfaction. In accordance with this, Wachs must take on the added responsibility of doing our best to assure the safest use of our equipment.

We have assembled a list of safety reminders to aid in creating the safest possible working environment. We recommend that the precautionary steps listed there be closely observed.



### Read the Following thoroughly before proceeding

#### 1. **READ THE OPERATING MANUAL!!**

Reading the setup and operating instructions prior to beginning the setup procedures can save valuable time and help prevent injury to operators or damage to machines.

#### 2. **INSPECT MACHINE & ACCESSORIES!**

Prior to machine setup physically inspect the machine and it's accessories. Look for worn tool slides, loose bolts or nuts, lubricant leakage, excessive rust, etc. A properly maintained machine can greatly decrease the chances for injury.

#### 3. **ALWAYS READ PLACARDS & LABELS!**

All placards, labels and stickers must be clearly legible and in good condition. Replacement labels can be purchased from the manufacturer.

#### 4. **KEEP CLEAR OF ROTATING PARTS!**

Keep hands, arms and fingers clear of all rotating or moving parts. Always turn machine off before attempting any adjustments requiring contact with the machine or it's accessories.

#### 5. **SECURE LOOSE CLOTHING & JEWELRY!**

Loose fitting clothing, jewelry; long, unbound hair can get caught in the rotating parts on machines. By keeping these things secure or removing them you can greatly reduce the chance for injury.

#### 6. **KEEP WORK AREA CLEAR!**

Be sure to keep the work area free of clutter and nonessential materials. Only allow those personnel directly associated with the work being performed to have access to the area if possible.

ALWAYS WEAR PROTECTIVE EQUIPMENT:

	<b>WARNING</b> Impact resistant eye protection must be worn while operating or working near this tool.
--	---

	<b>CAUTION</b> Personal hearing protection is required at all times when operating or working near this tool.
--	--

# TM-6 TRUCK MOUNTED VALVE OPERATOR

## SECTION Iii

## MACHINE SPECIFICATIONS

<b>CAPACITY:</b>	Operates all gate valves through 96"
<b>SPEED:</b>	5 to 30 revolutions per minute.
<b>SPEED CONTROL:</b>	Speed controlled by hydraulic flow at source.
<b>DRIVE:</b>	Dual, self lubricating , hydraulic motor drive to single ring gear. Balanced power load.
<b>MICROPROCESSOR:</b>	Pendant type. Water and shock resistant. Automatically operates valves in an exercising sequence compatible with industry standards. LCD readout displays revolution count (in tenths), operating torque, peak torque, torque limit and direction.
<b>TORQUE:</b>	Variable from 0 to 2500 ft/ lbs.
<b>RETROFIT:</b>	Retrofit available for Wachs TM-2, TM-3 and TM-5.
<b>CONTROL VALVE:</b>	Solenoid operated hydraulic directional control valve. On, off and direction.
<b>DIMENSIONS:</b>	25" wide x 51" long x 23" high. Requires 9.2 square feet of bed space.
<b>OIL TANK:</b>	19 gallon steel fabricated with sight guage.
<b>FILTRATION:</b>	10 micron canister type, easy change filter.
<b>VALVE KEY:</b>	2" square, high strength cold rolled tubing.
<b>SOCKET:</b>	2" square AWWA standard , universal type
<b>MISALIGNMENT CAPABILITY:</b>	12 degrees at power head.
<b>FRAME:</b>	Structural steel channel, fabricated.
<b>HEAD EXTENSION:</b>	21" from frame to center of head. 28" maximum.
<b>WEIGHT:</b>	370 lbs. dry weight.
<b>FINISH:</b>	Acrylic enamel paint ( yellow )
<b>AUXILIARY HYD. CIRCUIT:</b>	Integral power supply, provides 2000 psi @ 8 gpm.
<b>WARRANTY:</b>	1 year factory warranty against all defects in materials and workmanship
<b>PRODUCT SUPPORT:</b>	OEM training available on-site or at manufacturers facility.
<b>PRODUCT LIABILITY INS.</b>	Manufacturer shall maintain product liability.
<b>COMMERCIALY PROVEN:</b>	Manufacturer shall provide, upon request, evidence that the valve operator to be furnished has been commercially proven to the industry for not less than 1 year and replacement parts are readily available.

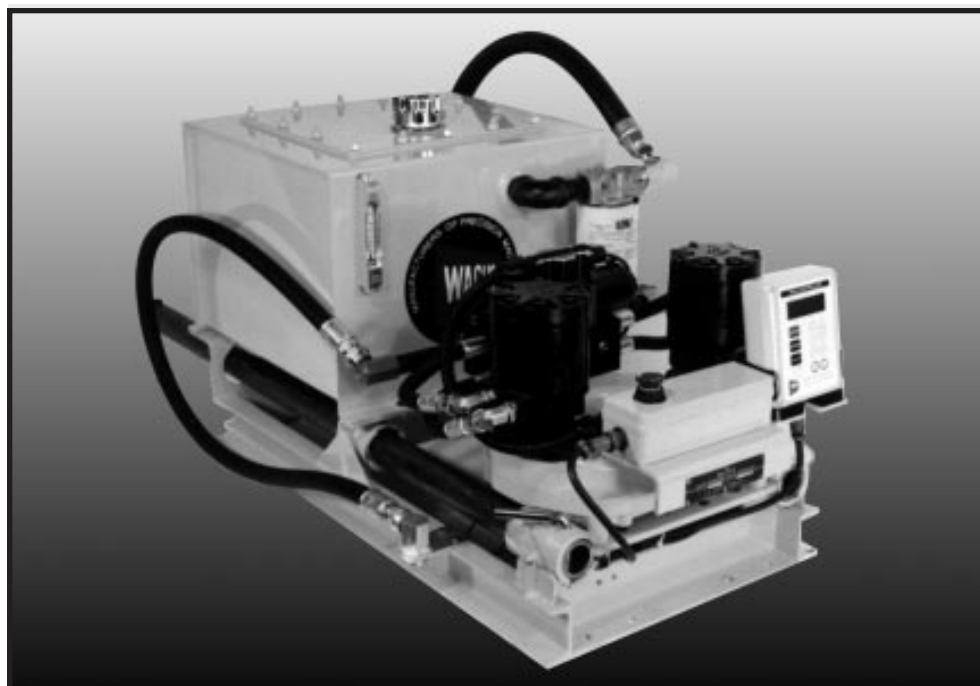

# TM-6 TRUCK MOUNTED VALVE OPERATOR

## SECTION IV

## SET-UP AND OPERATION

### A. INSTALLATION INSTRUCTIONS

1. Install a power take-off on truck transmission. See manufacturer's instructions included with power take-off. Be certain that rotation of power take-off shaft matches rotation of Hydraulic Pump as indicated by arrow on pump. PTO supplied by Wachs is normally installed on right (passenger) side of transmission unless specified otherwise.
2. Connect PTO control cable and mount red engagement knob assembly in desired location on dashboard. Control should be installed so that PTO will become engaged when pulled out.
3. The most satisfactory pump installation is direct flange mounted onto the PTO eliminating universal joints and drive shafts from PTO to remote mounted pump. If Wachs supplies the pump it will be a flange mounted with splined shaft for direct mount to PTO unless otherwise specified. If pump is purchased by customer from other than Wachs it must be capable of producing 14 GPM at 1200 RPM at 2000 PSI. NOTE: Do not operate pump until system is filled with oil.
4. Set valve operator in truck at desired location. Keep as close as possible to opening on side of body to assure maximum reach of power head when extended. Layout and drill eight (8) 9/16" mounting holes in truck bed for securing unit to the truck frame. (Ref. Fig. #2, Letter C on page 8).
5. Layout and cut two access holes in bed of truck: 1-3/8" access hole for 1" high pressure line (ref. #2, letter D on page 8) 2" access hole for 1-1/4" low pressure return line (ref. Fig. #2, Letter A on page 8). If access holes cannot be cut beneath connecting points on machine because of frame members, cut where clearance is available. Extra piping from access holes to connecting points may be needed. See Step 6.
6. Figure 3 shows suggested hose assemblies which should be purchased. High pressure hole should be 1" two wire braid capable of at least 1500 PSI working pressure. Return hose should be 1-1/4" rayon braid capable of at least 300 PSI working pressure. Hose ends should be male pipe thread. In figure 3 we recommend the use of 1" heavy wall pipe and 1-1/4" standard wall pipe for all connections through bed of truck. Pipe should extend under truck bed far enough to allow straight hose connec-

tions. Note that a swivel connection is necessary at one end of each hose.

7. Bolt Valve Operator to truck bed using 1/2" bolts through mounting holes (ref. #2, Letter C on page 8) cut in Step 4. If mounting bolts do not ground operator to frame of truck, connect ground strap from one bolt to frame.
8. Install piping and hoses assembled in Step 6. Use pipe tape on all connections. Use one to three hose clips to secure hose to underside of truck.
9. Connect red wire coming off of micro switch directly to battery positive terminal. Ground, or black wire, must make

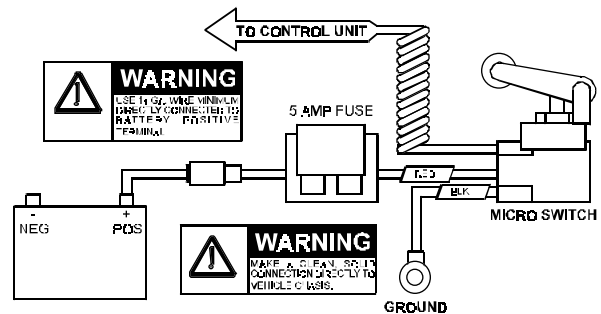

a solid connection directly to vehicle chassis ( See diagram above). A 14 gauge wire minimum should be used to make these connections.

10. Fill tank to full mark on gauge (approximately 22 gallons). Use hydraulic oil (Mobil, DTE light or equivalent).
11. Purchase and install hand throttle if truck is not equipped with one.
12. Test system by engaging PTO. Allow truck to idle for several minutes to purge air from system and check for hydraulic oil leaks.

See OPERATING INSTRUCTIONS before proceeding with operation.

13. Most truck body and equipment installers are familiar with installations of the type described above. This includes PTO, pump, hose lines and throttle controls.
14. If a door is cut in side of truck body for access to Valve Operator make it at least 25" wide and 17-1/4" high (14" high with direction control handle shortened) to allow power head to slide in and out.

# TM-6 TRUCK MOUNTED VALVE OPERATOR

## SECTION IV

## SET-UP AND OPERATION (cont.)

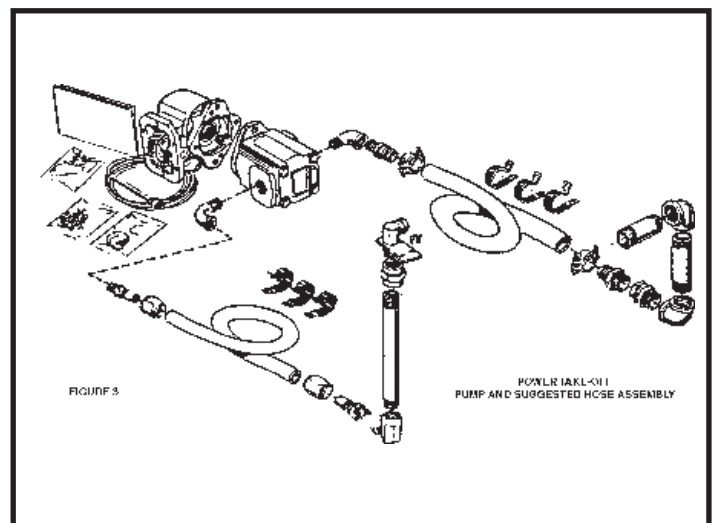
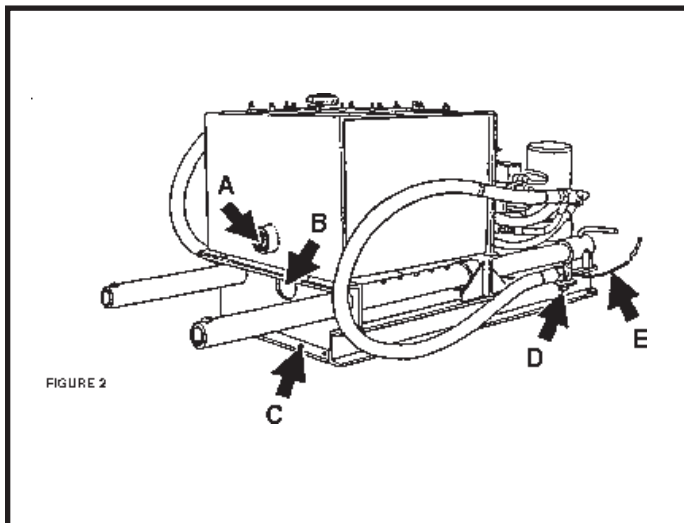
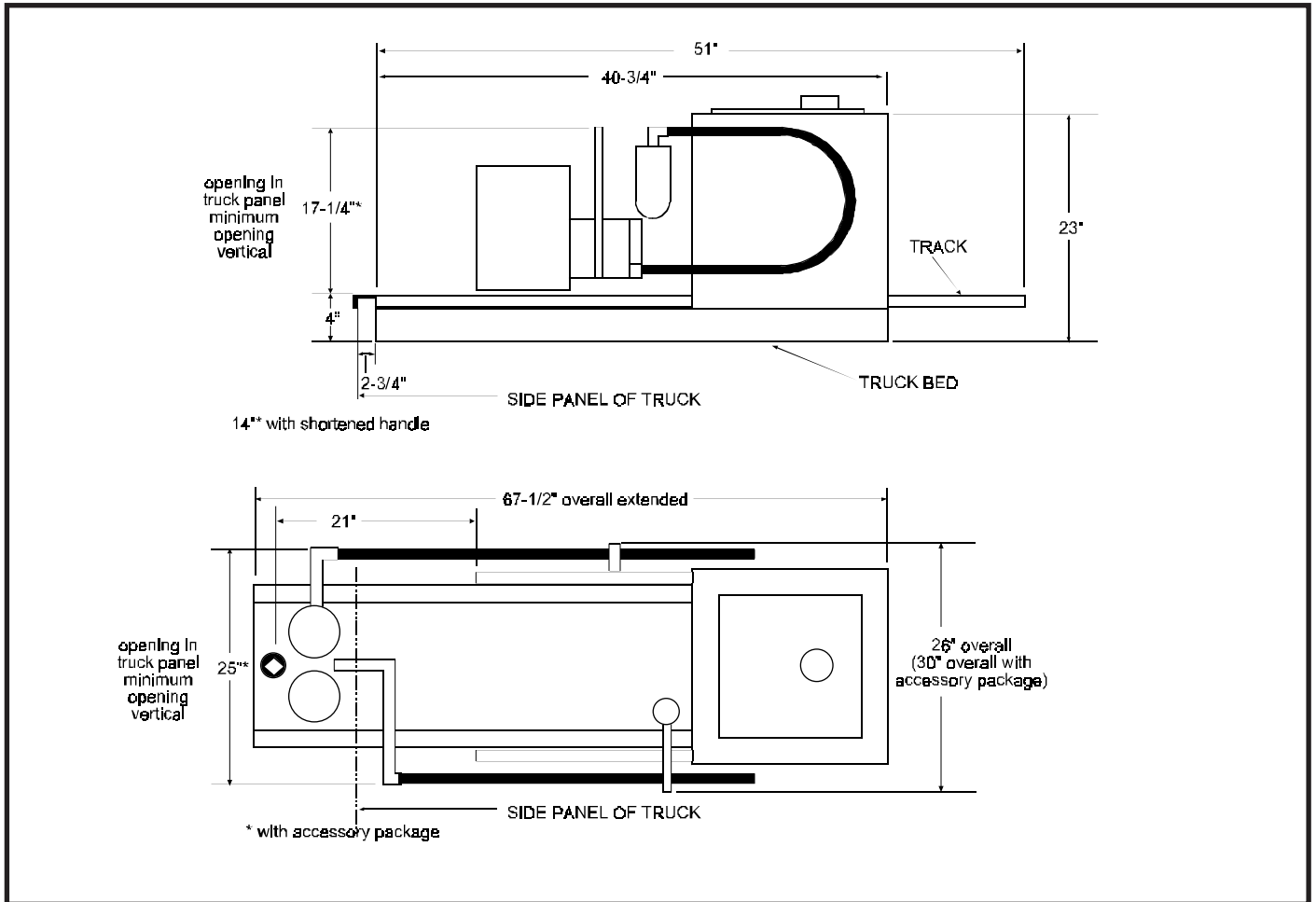



# TM-6 TRUCK MOUNTED VALVE OPERATOR

## SECTION IV

## SET-UP AND OPERATION (cont.)

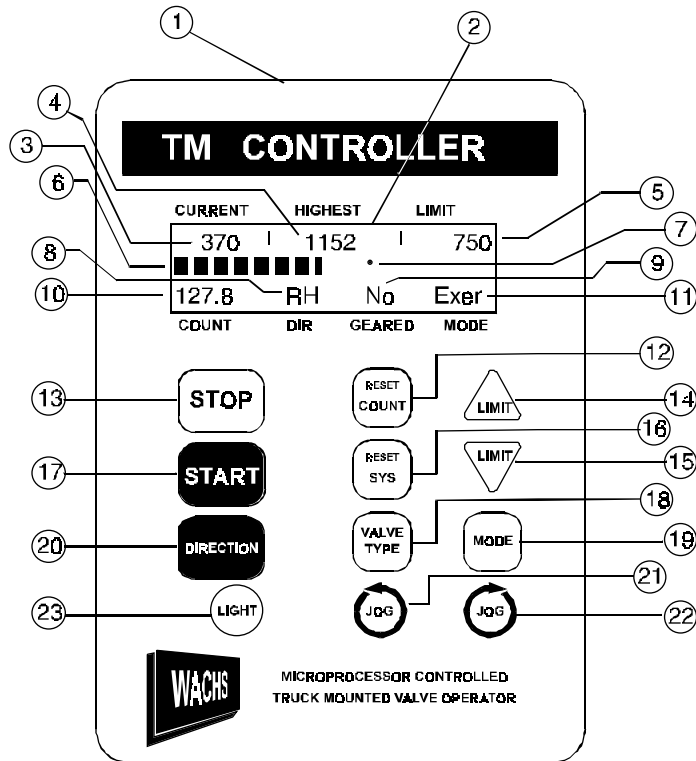

22. **JOG RIGHT:** Rotate power head right slightly.

23. **LIGHT:** Display light on/off.

**Other controls:**

### 1. Power Take-Off Control

The Valve Operator gets its power from the truck transmission through a hydraulic pump. Before operating a valve, the PTO knob must be actuated to engage the power take-off and start the hydraulic pump. Always push clutch in on standard transmission vehicles before engaging the PTO.

### 2. Truck Throttle

The speed of the Valve Operator is adjusted by changing the truck engine speed. The truck should have a lockable throttle in the cab, either original equipment or added later. The speed range of the Valve Operator is 5 to 30 RPM. When the truck is idling the Valve Operator should turn about 5 RPM.

### 3. Emergency Stop

The TM-6 is equipped with an emergency stop button located on top of the encoder / counter assembly housing.

## B. TM CONTROLLER

1. **TM-6 CONTROLLER PAD**
2. **LCD READOUT DISPLAY**
3. **CURRENT:** Torque being applied at that moment.
4. **HIGHEST:** Highest torque required to turn valve during cycle.
5. **LIMIT:** Indicates torque limit setting.
6. **TORQUE LEVEL INDICATOR BAR:** Measures torque being applied.
7. **TORQUE INDICATOR LEVEL:** Indicates maximum allowable torque being applied during a cycle.
8. **DIRECTION:** Primary turning direction chosen by program.
9. **GEARED:** Valve type selected, geared or non-geared.
10. **COUNT:** Revolution counter, counts in 10th's of a turn.
11. **MODE:** Operation mode selected- exercise or emergency.
12. **RESET COUNT:** Reset counter to zero.
13. **STOP:** Stop exercise.
14. **LIMIT:** Manually increase torque.
15. **LIMIT:** Manually decrease torque.
16. **RESET SYSTEM:** Clear all data.
17. **START:** Start exercise.
18. **VALVE TYPE:** Select valve type - geared or non-geared.
19. **MODE:** Select mode - exercise or emergency.
20. **DIRECTION:** Reset direction once operation cycle has been completed.
21. **JOG LEFT:** Rotate power head left slightly.

# TM-6 TRUCK MOUNTED VALVE OPERATOR

## SECTION IV

## SET-UP AND OPERATION (cont.)

### C. TM-6 OPERATION INSTRUCTIONS

The TM-6 is programmed to operate at the lowest torque required to maintain valve stem rotation. The torque limit, though adjustable, has a factory default at 200 ft./lbs.

The exercise, or "break loose" procedure, begins with operating torque programmed at 50 ft./lbs. If this torque is not sufficient to turn the valve stem, the direction of operation will reverse and apply torque. This procedure, the "No Assumption" method, which allows the microprocessor to determine direction of rotation, continues uninterrupted, increasing torque gradually, until the stem begins to turn or operating torque reaches the factory set torque limit. If the valve has not started to turn, the operator can increase the "TORQUE LIMIT" in increments of 50 ft./lbs per operating cycle. Once the valve stem has started turning, operating torque is reduced to the minimum torque required to keep it turning.

The "TORQUE LIMIT" is the maximum torque the TM-6 will apply to the valve during operation. When operating torque reaches the TORQUE LIMIT, exercising will stop automatically. This is usually an indication that the valve is fully opened or fully closed.

If additional torque increases are necessary, the limit may be increased once by pressing the limit key. TORQUE LIMIT increases are available only when operating torque has reached the TORQUE LIMIT. When operating torque drops well below the LIMIT, the LIMIT will decrease automatically.

When tuberculation, calcification or other deposits have built up on the valve stem or slides, rotation may become tight, requiring increased operating torque. The TM-6 will stop and automatically reverse direction temporarily. This helps to flush loosened debris from the stem threads and slides. Operation resumes automatically with increased operating torque. (Operating torque never exceeds the factory set TORQUE LIMIT.

When rotation becomes easier and less torque is required to turn the valve, operating torque automatically decreases to the lowest torque needed to maintain rotation.

#### OPERATION MODES

Three modes are available for valve exercising with the TM-6.

**EXERCISE MODE** provides the safest and most thorough valve exercising method. The torque limit may be increased only if the current limit is insufficient to turn the valve. When rotation becomes easier and operating torque decreases, the limit will decrement back to its original value. This ensures that the TM-6 uses only the minimum required torque.

**EMERGENCY MODE** is available when a valve must be closed in a hurry while still enforcing safe valve operation. Fewer reverses are induced and the torque limit remains at set point. At this point, the operator has full control of the set torque point.

**MANUAL MODE** is intended for the experienced operator. The torque set point is not in effect and operation stops only when operating torque reaches the torque limit. No forced reverses occur and the operator has full control of the torque limit (*this feature available only by request*).

#### VALVE TYPE SELECTION

Geared valves require a special consideration for proper exercising. To effectively clean the stem and slides, any up and down motions of the gate must occur through a greater number of turns than on a non-geared valve. Selecting a geared valve type will account for this by backing up further during temporary direction changes.

1. Position truck next to valve box.
2. Engage PTO and set engine speed.
3. Remove locking pins located to either side of the power head and pull the head out over the valve.
4. Insert the valve key into the power head. Use the right and left [ JOG ] keys, if necessary, to align the socket over the valve nut.
5. By using the TM-6 control pad, initialize the valve turning sequence by selecting the VALVE TYPE, either geared or non-geared, to be turned.
6. Select the MODE of operation. Choose from emergency or exercise.
7. Press the [ START ] button to begin exercise. Exercise will automatically stop when operating torque reaches the TORQUE LIMIT.
8. If TORQUE LIMIT has been reached and valve has not yet started to move, the control pad will flash the "insufficient torque" message. At this time the TORQUE LIMIT may be adjusted by using the limit keys.
9. When machine stops, check COUNTER to determine if the valve has reached the full open or full closed position.
10. Press the [ DIRECTION ] and the [ START ] buttons to exercise the valve in the opposite direction.
11. When complete, use the [ JOG ] keys, if necessary, to release the valve key and remove it from the valve nut.
12. Remove the valve key from the power head and slide it back into truck until locking pins can be replaced. Once head is secured, disengage PTO and move onto next valve.

# TM-6 TRUCK MOUNTED VALVE OPERATOR

## SECTION V

## MAINTENANCE

### Routine:

1. Keep slide bars greased to prevent rust and facilitate easy sliding of power head.
  2. Use a soft automotive grease in gear box, applied at grease fitting.
  3. Check oil level on gauge of hydraulic oil tank. Add oil if necessary. Keep hydraulic oil level at full mark on gauge.
  4. Oil temperatures should not exceed 180° F under prolonged or hard operating. If this temperature is exceeded, the hydraulic oil will break down and damage pump. The ample storage tank on the Wachs valve operator should assure proper oil temperature under normal conditions. If excessive temperatures are encountered, check oil level. If reservoir is full and high oil temperatures continue consult E.H. WACHS CO.
  - A. Change hydraulic filter on tank once a year – replacement filter can be purchased from WACHS.
  - B. Change hydraulic oil (Mobil, DTE light or equivalent) every two years. Note tank drain (ref. Fig. #2, Letter B).
  5. No lubrication attention is required on the two hydraulic motors as they are adequately lubricated by the hydraulic oil.
  6. Check **ALL** electrical connections regularly.
- For problems other than these, refer to Trouble Shooting section or call the E.H. WACHS COMPANY at 1-800/323-8185.

### ACCESSORIES:

#### **POWER TAKE-OFF (PART NO. 07-401-00)**

2 gear type, extra heavy duty to accept flange mounted hydraulic pump. Customer to provide truck model, year and transmission model when ordering.

#### **HYDRAULIC PUMP (PART NO. 07-402-00)**

To supply power for Truck Mounted Valve Operator. Customer to specify either flange mount for direct mount to PTO listed above or foot mount for remote mounting and connection through Universal Joint and shaft to customer's PTO.

#### **AUXILIARY POWER PACKAGE (PART NO. 07-404-00)**

Consisting of Pressure Relief Valve, Shut-Off Valve and piping; installed on Truck Mounted Valve Operator to provide power for auxiliary hydraulic equipment such as the Wachs Pump and Portable Valve Actuator.

#### **THROTTLE CONTROL (PART NO. 07-405-00)**

Locking "T" handle type for controlling truck engine speed.

#### **EXTRA VALVE KEYS (PART NO. 07-406-00)**

Heavy-duty 2" square keys drilled both ends to accept socket or key adaptor. Customer to specify length desired.

#### **KEY ADAPTOR (PART NO. 07-407-00)**

Male union for joining keys including two detent pins.

#### **EXTRA UNIVERSAL SOCKET (PART NO. 07-408-00)**

2" square ductile iron socket to fit Wachs 2" square keys and standard A.W.W.A. nut.

#### **EXTRA FILTER ELEMENT (PART NO. 07-139-00)**



# TM-6 TRUCK MOUNTED VALVE OPERATOR

## Section VI

### **TM-6 / TM-6B TROUBLESHOOTING**

# TM-6 TRUCK MOUNTED VALVE OPERATOR

## SECTION VI

## TM-6 TROUBLESHOOTING

Trouble	Possible Cause	Remedy
Dead battery.	Head retracted and latched but display stays on.	Adjust Micro Switch in housing to switch off when head is retracted and latched. Charge battery.
No display.	Dead battery.	See above.
	No power to head.	Pull out head to engage Micro Switch.
	Disconnected or defective cable.	Check cable and power connections (see wiring diagrams). Test control cable leads to insure continuity. Replace defective cables.
Machine does not operate.	Pump not engaged.	Engage pump or PTO.
	Auxilliary circuit engaged.	Push auxilliary valve in completely to disengage.
Encoder error.	Pump not engaged.	Engage pump or PTO. Verify drive hub rotation by pressing JOG keys in both directions.
	Poor electrical connection.	Check electrical connections (see wiring diagram).
	Encoder failure.	Replace Encoder.
	Defective Solenoid Valve.	Using JOG keys, rotate drive hub in both directions. While jogging, observe indicator lights on top of valve. If either light fails, check electrical connections and power control board. If both lights illuminate but head fails to rotate in one or both directions replace valve.

# TM-6 TRUCK MOUNTED VALVE OPERATOR

## SECTION VI

## TM-6 TROUBLESHOOTING (cont.)

Trouble	Possible Cause	Remedy
Encoder Error	Relay failure.	Replace Relay.
	Defective control unit.	Replace or return for service.
	Damaged Cable.	Replace Cable.
TRANSDUCER ERR displayed.	Poor electrical connection.	Check electrical connections (see wiring diagram).
	Pressure transducer failure.	Check transducer voltage output at green wire. Voltage should read between .5 and 5V. Replace if not within tolerance.
	Defective control unit.	Replace or return for service.
EMERGENCY STOP ERR displayed.	Damaged Cable.	Replace Cable.
	Electrical noise.	Turn off vehicle accessories.
	Defective Relay.	Replace Relay.
	Defective Control Unit.	Replace or return for service.
	Damaged Encoder.	Replace Encoder.
Low Power.	Poor electrical connection.	Repair connection. Make sure proper installation procedure was followed.

# TM-6 TRUCK MOUNTED VALVE OPERATOR

## SECTION VI

## TM-6B TROUBLESHOOTING

Trouble	Possible Cause	Remedy
Dead battery	Machine stored with head extended.	Retract and latch head for storage. Charge battery.
	Head retracted and latched but display stays on.	Adjust Micro Switch in housing to switch off when head is retracted and latched. Charge battery.
No display	Dead battery.	See above.
	No power to head.	Pull out head to engage Micro Switch.
	Disconnected or defective cable.	Check cable and power connections (see wiring diagrams). Test control cable leads to insure continuity. Replace defective cables.
Machine does not operate	Pump not engaged.	Engage pump or PTO.
	Auxilliary circuit engaged.	Close auxilliary valve.  Push auxilliary valve in completely to disengage.
	COUNTER ERR displayed.	Replace fuse (see Kohler engine manual)
COUNTER ERR displayed.	Pump not engaged.	Engage pump or PTO. Verify drive hub rotation by pressing JOG keys in both directions.
	Poor electrical connection.	Check electrical connections (see wiring diagram).
	Encoder failure.	Replace Encoder
	Defective Solenoid Valve.	Using JOG keys, rotate drive hub in both directions. While jogging, observe indicator lights on top of valve. If either light fails, check electrical connections and power control board. If both lights illuminate but head fails to rotate in one or both directions replace valve.



# TM-6 TRUCK MOUNTED VALVE OPERATOR

## SECTION VI

## TM-6B TROUBLESHOOTING (cont.)

Trouble	Possible Cause	Remedy
COUNTER ERR displayed.	Power control board failure.	Unplug and replace power control board.
	Damaged cable.	Replace Cable.
	Defective control unit.	Replace or return for service.
TRANSDUCER ERR displayed.	Poor electrical connection.	Check electrical connections (see wiring diagram).
	Pressure transducer failure.	Check transducer voltage output at green wire. Voltage should read between .5 and 5V. Replace if not within tolerance.
	Defective control unit.	Replace or return for service.
	Damaged Cable.	Replace Cable.
BYPASS ACTV displayed.	Electrical noise.	Press STATRT. If message clears problem is false signal caused by electrical noise. Consult your factory representative if problem persists.
	Power Control Board failure.	Unplug and replace Power Control Board.
	Defective Control Unit.	Replace or return for service.



Section VII

**OPERATION  
MODE  
COMPARISON TABLE**

# TM-6 TRUCK MOUNTED VALVE OPERATOR

## SECTION VII

## OPERATION MODE COMPARISON TABLE

Operation Mode	<i>Exercise</i>	<i>Exercise</i>	<i>Emergency</i>	<i>Emergency</i>	<i>Manual</i>
Valve Type (Geared Yes/No)	No	Yes	No	Yes	Not Available
Torque limit increases always available?	No	No	Yes	Yes	Yes
Torque limit increment (when available)	50 ft-lb	100 ft-lb	100 ft-lb	100 ft-lb	100 ft-lb
Automatic torque limit decrement rate*	50 ft-lb. per 0.5 turns	50 ft-lb. per 1.5 turns	None	None	None
Automatic set point increment	50 ft-lb.	50 ft-lb.	100 ft-lb.	100 ft-lb.	None
Automatic set point decrement rate**	50 ft-lb. per 0.5 turns	50 ft-lb. per 1.5 turns	50 ft-lb. per 0.5 turns	50 ft-lb. per 1.5 turns	None
Attempts required at each set point	2	2	1	1	1
Number of turns during forced reverse***	0.5/3	1.5/10	0.5	1.5	None
Condition to require operator input	Set point reaches limit and 'attempts required' is satisfied.				

\* Limit will decrement if the difference between limit and set point is more than two set point increments (exercise mode only).

\*\* Set point will decrement if the difference between set point and operating torque is more than 100 ft-lb.

\*\*\* In exercise mode, when set point is less than limit, reverses are short and intended only to clear valve nut and stem threads (first number shown above applies). In emergency mode, all reversing is intended only to clear valve nut and stem threads.

Section VIII

**PARTS LISTS  
AND  
EXPLODED VIEW  
DRAWINGS**

# TM-6 TRUCK MOUNTED VALVE OPERATOR

## TM-6 Head Assembly

REF.	PART NO.	QTY.	DESCRIPTION
1	70-001-00	1	GEAR HUB
2	70-002-00	4	DRIVE PIN
3	07-003-00	1	DRIVE HUB
4	07-005-01	1	GEAR BUSHING
5	07-006-01	1	UPPER THRUST WASHER
6	07-006-02	1	LOWER THRUST WASHER
7	07-009-00	1	BULL GEAR
8	07-036-00	1	TOP HOUSING
9	07-037-00	1	BOTTOM HOUSING
10	07-100-00	1	RETAINING RING
57	07-072-00	2	MOTOR, HYDRAULIC
78	07-008-00	2	GEAR, PINION
79	07-018-00	2	RETAINING RING
<b>FASTENERS</b>			
REF.	PART NO.	QTY.	DESCRIPTION
01	90-056-03	4	PIN, DOWEL 1/4 x 3/8
02	90-060-06	8	SHCS, 5/16-18 x 5/8
03	90-070-07	6	SHCS, 3/8-16 x 3/4
04	90-070-17	6	SHCS, 3/8-18 x 1-3/4
05	90-070-12	4	SHCS, 3/8-16 x 1-1/4
06	90-070-25	4	SHCS, 3/8-16 x 2-1/2
07	90-095-02	4	HEX NUT, 1/2-20
08	90-500-03	1	GREASE FITTING 1/8 N.P.T.
037	90-092-12	8	BHCS 1/2-13 x 1-1/4
069	90-062-07	8	5/16-18 x 1/2 BHCS

# TM-6 TRUCK MOUNTED VALVE OPERATOR

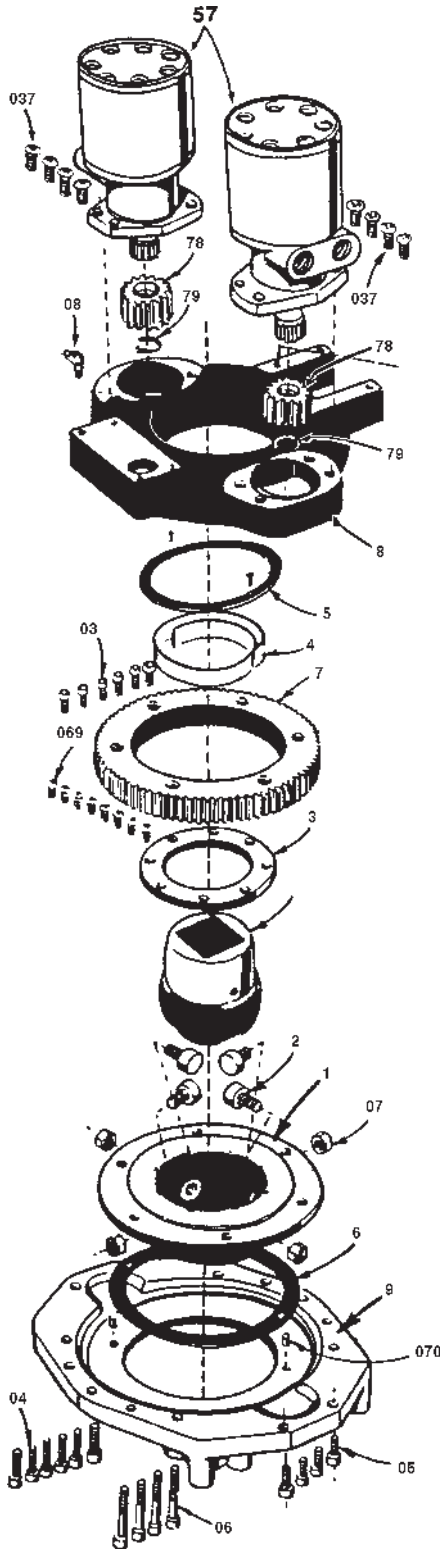

# TM-6 TRUCK MOUNTED VALVE OPERATOR

## TM-6 Manifold Assembly

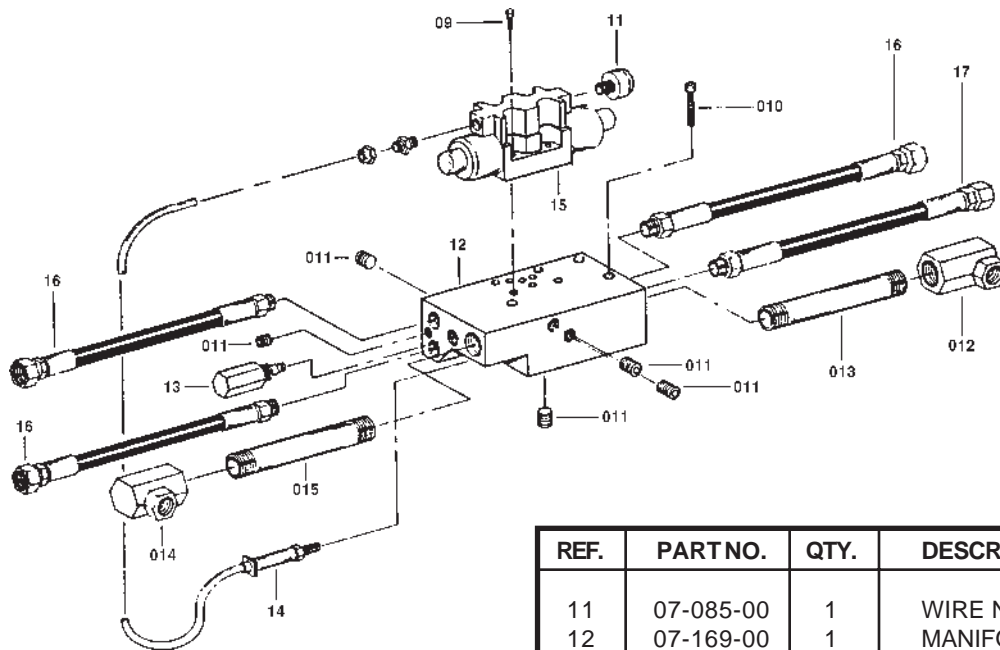

REF.	PART NO.	QTY.	DESCRIPTION
11	07-085-00	1	WIRE NUT
12	07-169-00	1	MANIFOLD
13	07-172-00	1	VALVE
14	07-171-00	1	TRANSDUCER
15	07-170-00	1	RELIEF CARTRIDGE
16	07-173-00	3	HOSE
17	07-174-00	1	HOSE
18	07-089-00	1	HOSE, PRESSURE N/S
19	07-090-00	1	HOSE, RETURN N/S
20	07-176-00	1	CONNECTOR
21	11-004-00	1	CONNECTOR CORD
22	62-138-00	18	TUBING 3/8"

### FASTENERS

REF.	PART NO.	QTY.	DESCRIPTION
09	90-050-15	4	SHCS, 1/4-20 x 1-1/2
010	90-060-32	3	SHCS, 5/16-18 x ~1 /4
011	90-059-62	5	PLUG, NPT 1/4
012	90-218-54	1	EL w/SWVL 3/4-90
013	90-218-59	1	NIPPLE 3/4 x 6 HP
014	90-238-51	1	ELBOW w/ SWVL 1'-90
015	90-238-72	1	NIPPLE, 1 x 6-1/2 LP
016	90-501-08	1	TERMINAL #8 BLU N/S
017	90-501-11	3	TERMINAL #8 RED N/S
018	90-501-39	3	TERMINAL #8 RED N/S
019	90-901-01	3	WIRE 18 GA RED N/S
020	90-901-02	2.5FT	WIRE 18GA BLACK N/S
021	90-901-03	2.5FT	WIRE 18GA BLUE N/S
022	90-901-04	2.5FT	WIRE 18GA YELLOW N/S



# TM-6 TRUCK MOUNTED VALVE OPERATOR

## TM-6 Housing Assembly\*

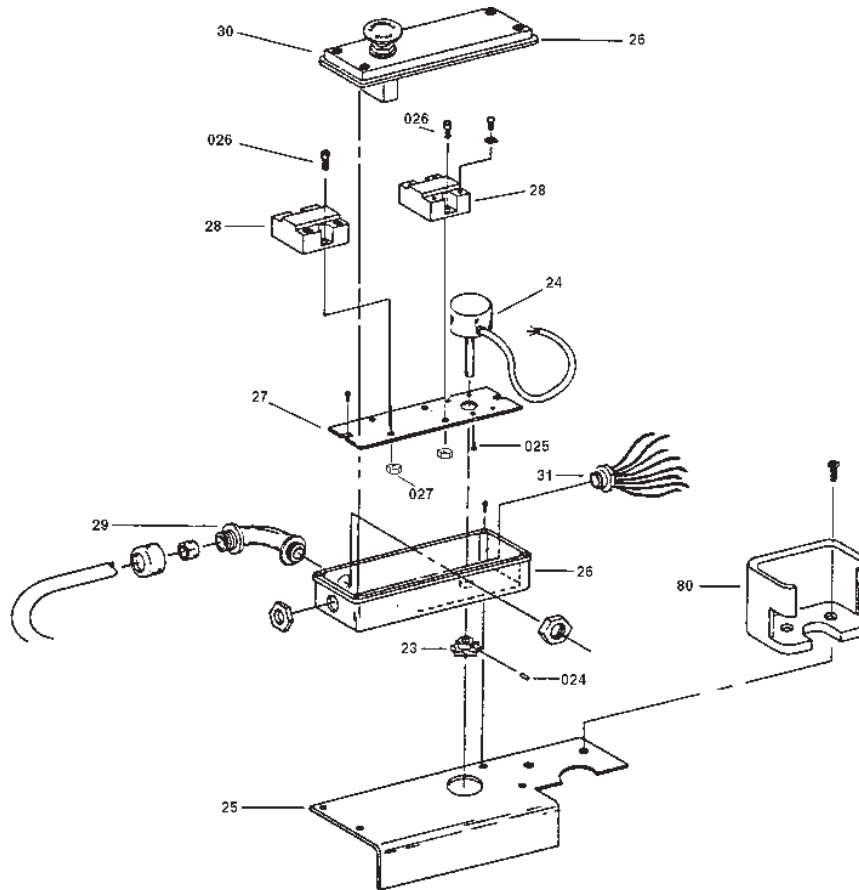

REF.	PARTNO.	QTY.	DESCRIPTION
23	07-050-00	1	PINION COUNTER
24	07-093-00	1	ENCODER
25	07-106-00	1	PLATES/N
26	07-177-00	1	ENCLOSURE
27	07-178-00	1	PANEL
28	07-179-00	2	RELAY
29	07-180-00	1	PIGTAIL
30	07-195-00	1	EMERGENCY SWITCH
31	62-137-00	1	CONNECTOR
80	07-182-00	1	CONTROL PAD HOLDER
FASTENERS			
REF.	PARTNO.	QTY.	DESCRIPTION
023	90-009-01	3	RHMS 6-32 x 1/4
024	90-016-56	1	ROLL PIN 3/32 x 5/8
025	90-020-06	4	SHCS 8-32 x 5/8
026	90-040-03	4	SHCS 10-24x3/8
027	90-045-03	4	NUT, HEX 10-24
028	90-049-01	6	SCREW 3/16

\*NOTE: If your Valve Exerciser has been upgraded to a TM-6B or a TM-6DT, please also refer to pages 26-27 which is a supplement to this page.

# TM-6 TRUCK MOUNTED VALVE OPERATOR

TM-6 B UPGRADE (07-307-01, 02)

REF.	PARTNO.	QTY.	DESCRIPTION
2	07-050-00	1	PINION,COUNTER
3	07-093-00	1	ENCODER,PHOTOCRAFT
11	07-182-00	1	STAND
14	17-304-00	1	TMC2CONTROLLER
15	62-137-00	1	CONNECTOR,3/8x90
23	90-016-56	1	PIN,ROLL,3/32 X 5/8
31	07-106-00	1	PLATE,SW
n/s	07-198-00	1	TAG
33	07-209-00	1	HANDLE
34	07-210-00	2	STAND-OFF
35	07-224-00	1	ENCLOSURE,MOD
36	07-211-00	1	PLUG,ENCLOSURE
37	07-212-00	1	BRACKET,ENCODERMGTG
38	07-214-00	1	SWITCH,MOD
39	07-215-00	1	PUSHBUTTON,E-STOP
40	07-216-00	1	BLOCK,CONTACT
41	07-217-00	2	GROMMET
42	07-218-00	1	SEAL,ENCODER
43	07-219-00	1	O-RING,ENCODER
n/s	07-220-00	1	HOLDER,FUSE
n/s	07-221-00	1	FUSE,6AMP
46	07-222-00	0.5	CORD,POWER
47	07-223-00	2	STRIP,FOAM
48	11-004-00	2	CONNECTOR,CORD
49	17-028-00	1	BOARD,POWER CONTROL
50	17-029-00	4	GROMMET
51	17-030-00	1	BATTERY
52	17-032-00	1	CABLE,CONTROL
53	17-033-00	1	GRIP,CABLE
54	90-001-06	3	SHCS,6-32 x 5/8
55	90-050-07	4	SHCS,1/4-20 X 3/4
56	90-051-05	4	HHCS,1/4-20 X 1/2
57	90-059-25	4	RHMS,1/4-20 x 1/2
n/s	90-501-39	2	TERM#8REDFORK
n/s	90-901-09	1	WIRE,18GAWHITE

# TM-6 TRUCK MOUNTED VALVE OPERATOR

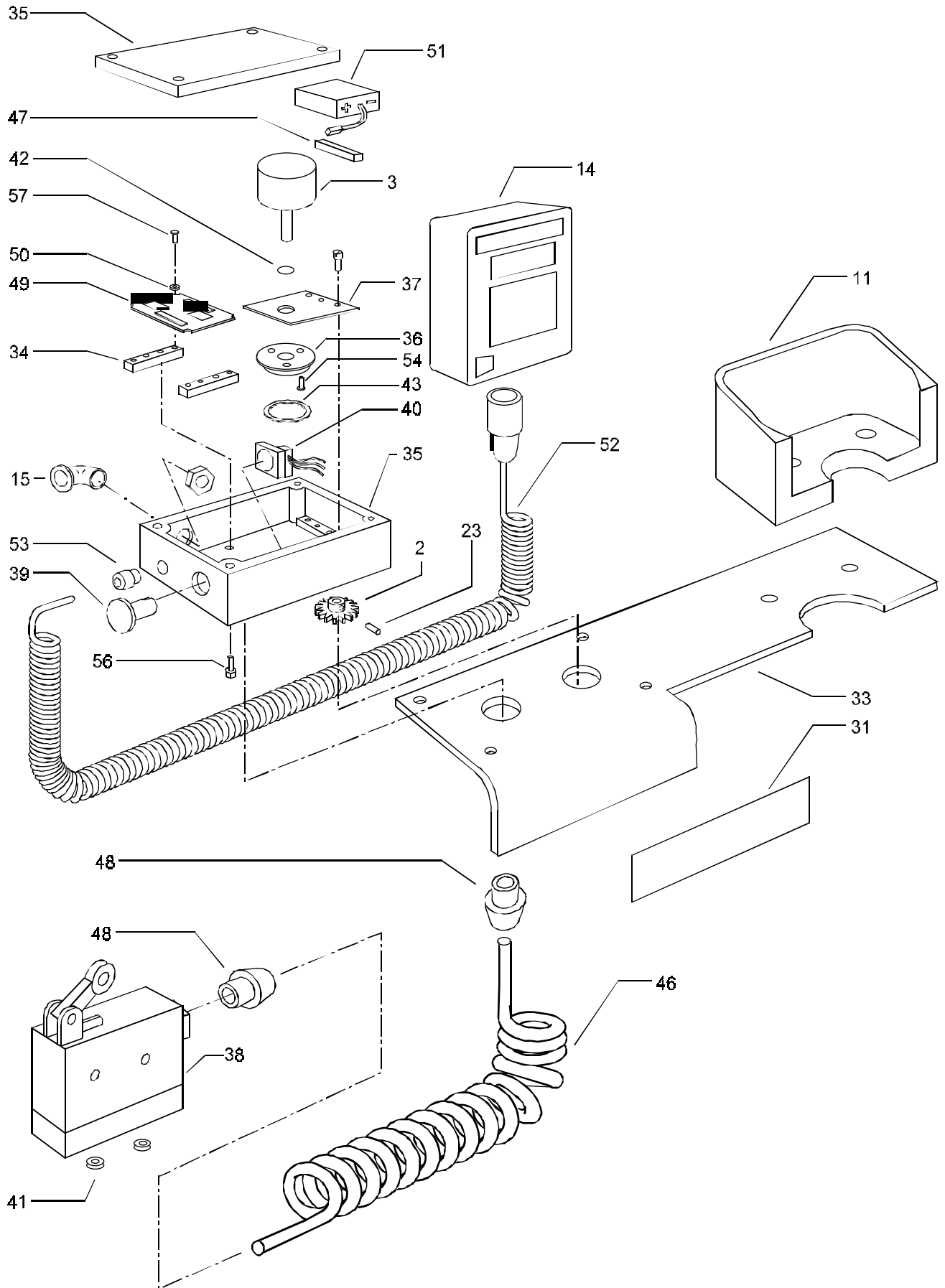

# TM-6 TRUCK MOUNTED VALVE OPERATOR

## SECTION IX TM 6 PARTS LISTS & EXPLODED VIEW DRAWINGS

REF	PART NO	QTY	DESCRIPTION	REF	PART NO	QTY	DESCRIPTION
18	07-089-00	1	HOSE, PRESSURE	045	90-208-51	2	ADAPTOR 5/8 x 5/8 JIC
19	07-090-00	1	HOSE, RETURN	046	90-501-06	1	TERMINAL 1/4" MALE
32	07-020-00	1	BASE, SLIDING	047	90-501-00	1	FEMALE, SPADE .250
33	07-023-00	2	PIN, SLIDE LOCKING	048	90-501-11	1	TERMINAL #6 RED
34	07-024-00	18	WIRE, RETAINING	049	90-501-37	4	TERMINAL #6 RED
35	07-025-00	1	PLATE HP HOSE	050	90-501-39	2	TERMINAL #8 RED
36	07-029-00	1	FILTER ASSEMBLY	051	90-901-05	2	WIRE 14 GA. RED
37	07-045-00	4	SLEEVE, RETAINING WIRE	052	90-901-06	2	WIRE 14 GA. BLACK
38	07-055-00	1	PLATE VALVE MOUNTING	066	90-238-52	1	1" ST. EL W/ SWIVEL
39	07-056-01	1	TANK ASSEMBLY	067	90-218-17	1	3/4" x 90° ELBOW
40	07-057-00	1	FRAME ASSEMBLY	068	90-075-53	1	3/8" FLAT WASHER
41	07-150-00	1	CRATE SHIPPING				
42	07-406-08	1	8" VALVE KEY				
43	07-034-00	2	UNIVERSAL SOCKET				
44	07-035-00	1	CENTER BLOCK				
45	07-134-00	2	UNIVERSAL SOCKET PIN				
46	14-124-00	1	FILLER CAP ASSEMBLY				
47	14-125-00	1	OIL LEVEL GUAGE				
48	07-062-00	1	TANK GASKET				
49	07-139-00	1	FILTER CANISTER				
50	07-041-00	1	SWITCH, MICRO				
51	07-046-00	1	CLAMP, CABLE				
52	07-140-00	1	FUSE HOLDER				
53	07-143-00	1	5 AMP FUSE				
54	07-142-00	36"	POWER CORD				
55	07-008-00	1	GEAR PINION				
56	07-018-00	2	RETAINING RING				
57	07-072-00	2	HYDRAULIC MOTOR				
58	07-304-00	1	*CONTROL PAD ASSEMBLY*				
<b>FASTNERS</b>							
012	90-218-54	1	ELBOW W/ SWIVEL 3/4"-90°				
014	90-218-51	1	ELBOW W/ SWIVEL 1"-90°				
029	90-054-02	4	SSS 1/4-20 x 1/4				
030	90-079-21	2	PIN, FAST 3/8 x 2-7/8				
031	90-051-01	2	HHCS 1/4-20 x 1"				
032	90-055-01	2	HEX NUT 1/4-20				
033	90-055-52	2	LOCK WSHR SPLT RING 1/4"				
034	90-072-07	4	BHCS 3/8-16 x 3/4				
035	90-075-01	4	NUT, HEX 3/8-16				
036	90-092-10	10	BHCS 1/2-13x1				
037	90-092-12	8	BHCS 1/2-13 x 1-1/4"				
038	90-095-01	2	NUT HEX 3/8-16				
039	90-218-01	1	NIPPLE, CLOSE 3/4 LP				
040	90-218-05	1	PLUG SQUARE HEAD 3/4				
041	90-218-07	1	ELBOW 3/4-90"				
042	90-238-01	1	NIPPLE CLOSE 1"LP				
043	90-238-02	1	NIPPLE 1x2-1/2"				
044	90-238-05	1	ELBOW 1"-90				

\*CONTROL PAD CONTAINS NO USER SERVICEABLE COMPONENTS.

# TM-6 TRUCK MOUNTED VALVE OPERATOR

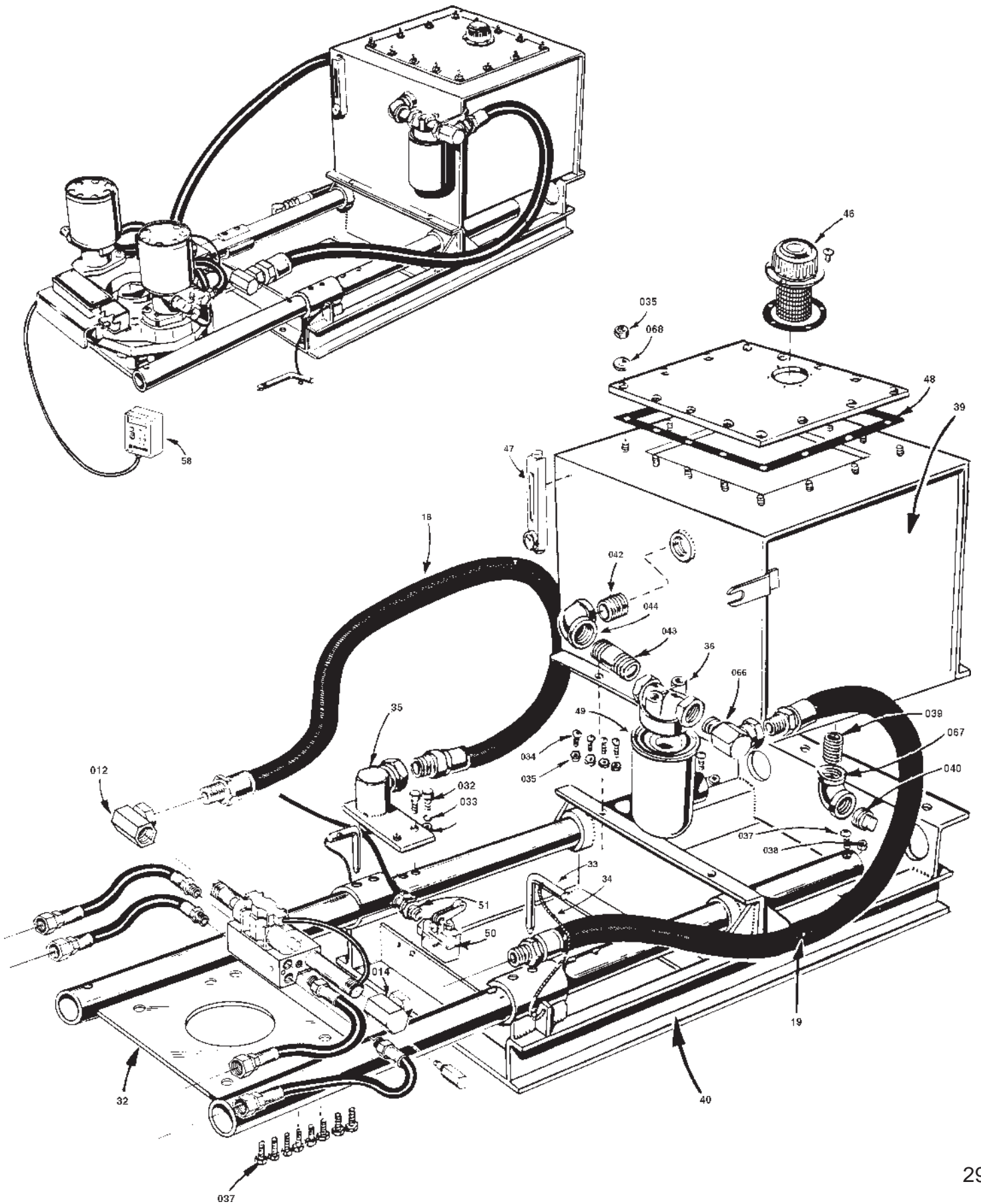



## Section IX

### **WIRING DIAGRAMS AND VALVE EXERCISING LOG**

# TM-6 TRUCK MOUNTED VALVE OPERATOR

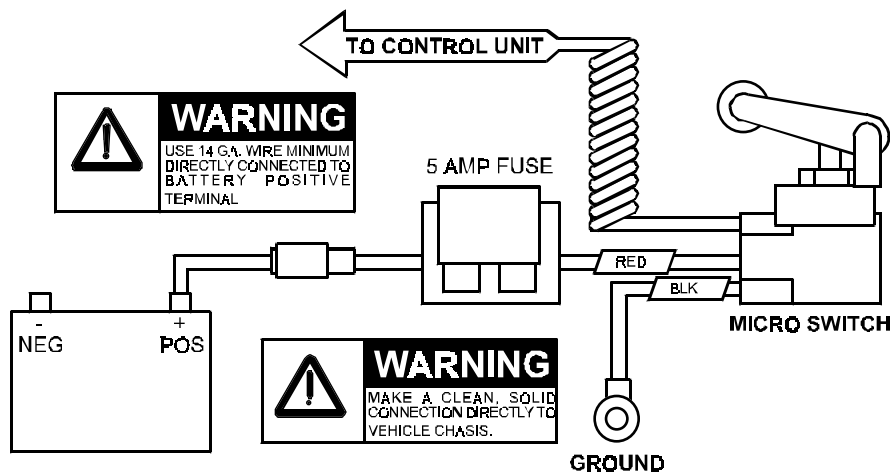
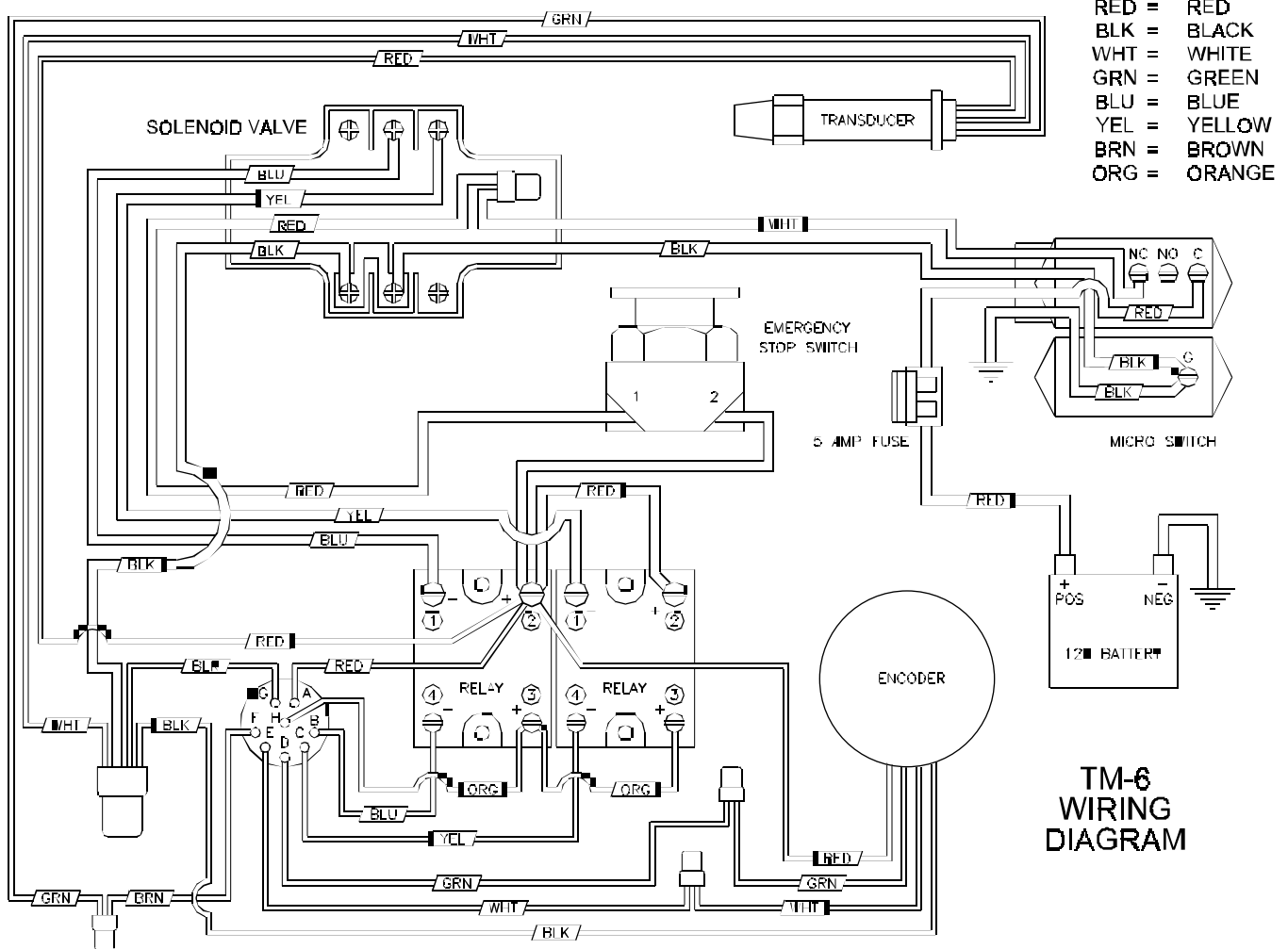



# TM-6 TRUCK MOUNTED VALVE OPERATOR

## TM-6B WIRING DIAGRAM

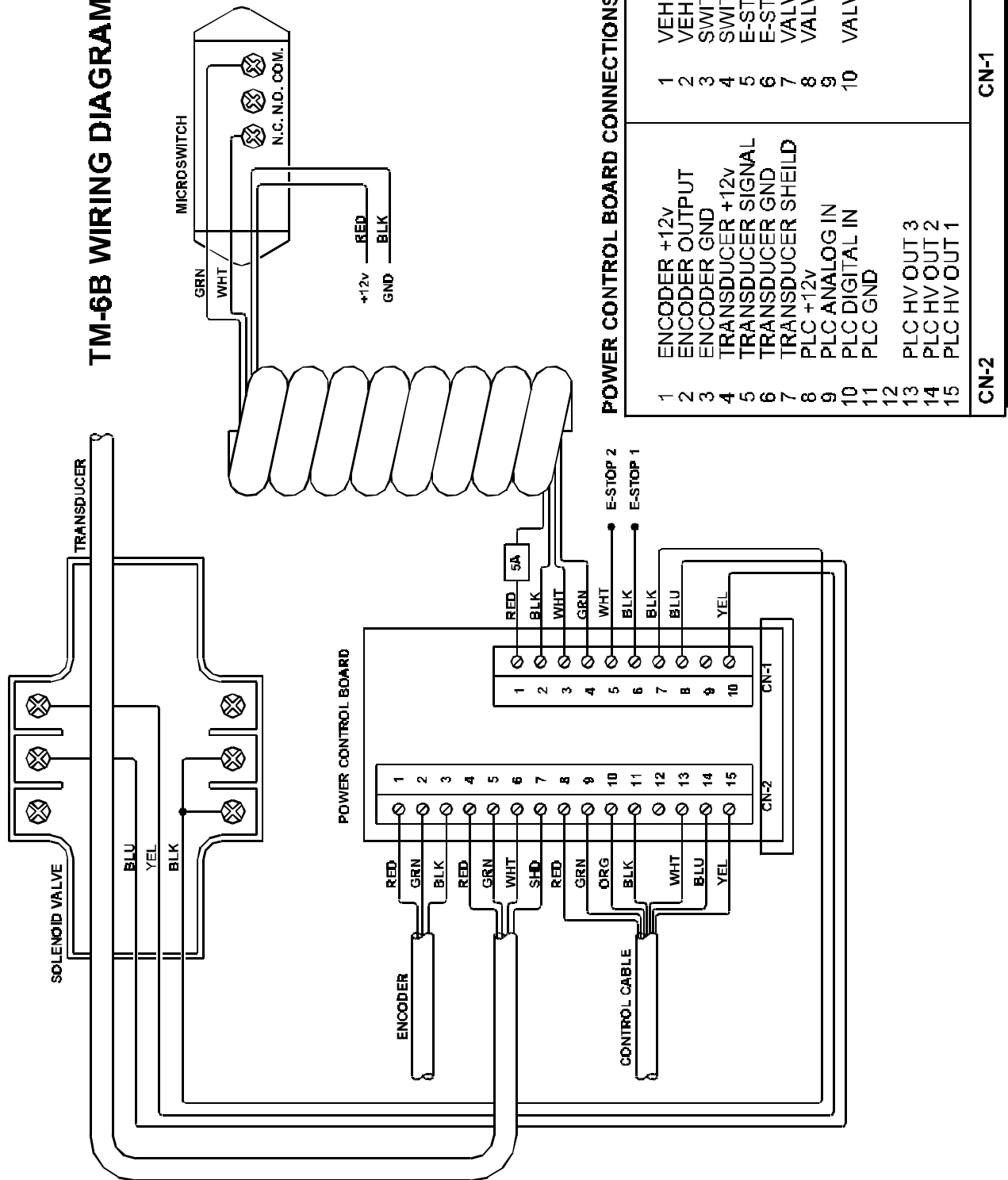





# TM-6 TRUCK MOUNTED VALVE OPERATOR

## SECTION X

## ORDERING INFORMATION

### ORDERING

To place an order or to get more detailed information on any E.H. Wachs products, call us at:  
1-800-323-8185.

### ORDERING REPLACEMENT PARTS

Please use parts list provided in manual. Have part description and part number of required replacement part or parts to help expedite order and insure proper parts are being ordered.

### REPAIR INFORMATION

Please call E.H. Wachs Company prior to returning any equipment for repair. We will advise you of shipping and handling. Please enclose with equipment to be repaired your name, address, phone number and a brief description of problem or work to be done or estimated.

All repair work done at our plant will be estimated and the customer advised of cost and time required to complete repair.

### WARRANTY INFORMATION

Enclosed with the manual is a warranty card. Please fill out the registration card and return to E.H. Wachs. Retain the owners registration record and warranty card for your information.

### RETURN GOODS ADDRESS

E.H. Wachs Company  
600 Knightsbridge Parkway  
Lincolnshire, IL 60069

	<b>PIPE &amp; VALVE</b>
	<b>MAINTENANCE PRODUCTS</b>
Mod. <b>TM-6, 6B</b> S/N: <input type="text"/> <input type="text"/> <input type="text"/> <input type="text"/> <input type="text"/> <input type="text"/> <input type="text"/>	
E.H. Wachs Company 600 Knightsbridge Parkway, Lincolnshire, IL 60069	

847-537-8800

FAX: 847-520-1147 • 847-520-1168

Toll-Free: 1-800-323-8185